

Product catalogue

# Horn Antennas



Q-par Angus Ltd

IDEAS ENGINEERED

# Design Production Testing

Years of RF design experience and the latest modelling software allow us to design horn antennas to our customers' particular technical specifications. Gain, beamwidth and operational power level requirements are integrated into the design process at the outset, whilst mechanical and environmental considerations are also very often major contributing factors.

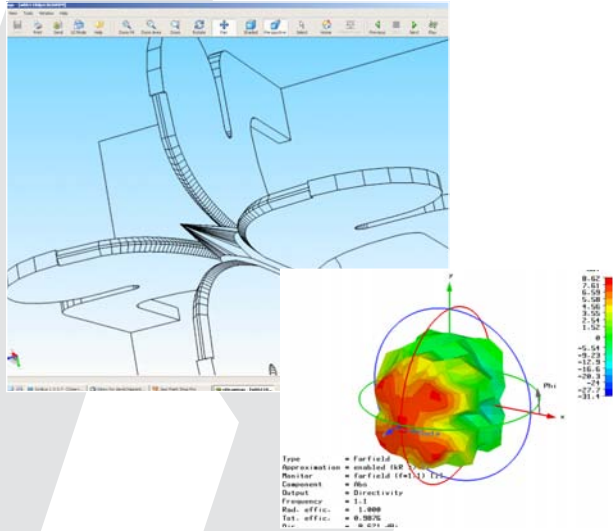

Our fully equipped workshops undertake all of our general manufacturing, whilst specialised processes such as laser cutting and wire-erosion are sub contracted. Welded horns range from WG4 to WG16, while our electroforming facility allows us to produce millimetric horns.

Many of our more exotic horn antennas require very demanding manufacturing tolerances, a routine aspect of the work carried out by our team of highly skilled technicians.



Once realised 'in the metal', our horns are fully tested to the required specifications using a comprehensive range of calibrated and traceable to national standards test equipment.

Radiation patterns and gain measurements are made either within our anechoic chamber, or on one of our outdoor test ranges.

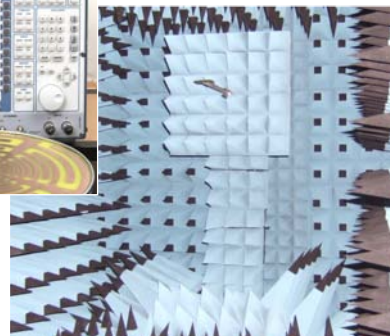
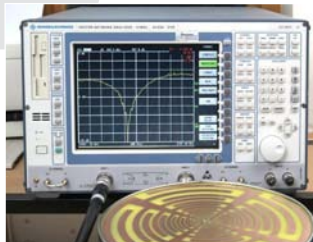

# Finish Mounting Radomes

A number of radome options are available. These range from a simple, functional cover to prevent the ingress of dirt or airborne particles, to much more sophisticated pressure tested radomes, designed to withstand the internal pressurisation often used in high power applications such as EMC testing.

Extreme environmental conditions can also dictate further measures to maintain both electrical and mechanical integrity and longevity.

We also design and manufacture radomes used for beam forming applications.

Simple rear mounting plates are standard on most of our horn antennas, with centre of gravity mounting points provided on heavier and larger models. These allow mounting in two polarisations by removal and refitting, but we can also provide the facility for 'polarisation rotation', whereby the antenna can be moved through a range of angles of polarisation and locked in position.



Our horn antennas are usually supplied painted white or powder coated light grey. The millimetric antennas are usually gold plated.

We are also happy to supply any specified paint colour or custom finish.

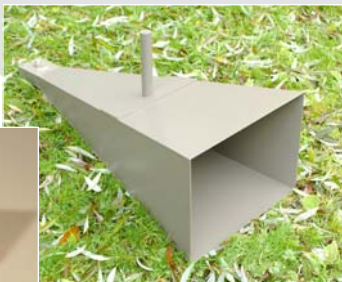
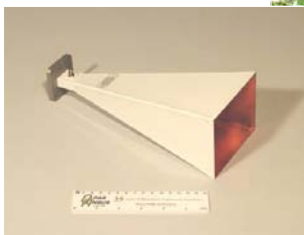

# Standard Waveguide Number Chart

Freq. GHz	WG	WR	R
0.75 - 1.1	4	975	9
0.9 - 1.5	5	770	12
1.1 - 1.7	6	650	14
1.4 - 2.2	7	510	18
1.7 - 2.6	8	430	22
2.2 - 3.3	9A	340	26
2.6 - 4.0	10	284	32
3.3 - 4.9	11A	229	40
3.9 - 5.9	12	187	48
4.9 - 7.1	13	159	58
6.0 - 8.2	14	137	70
7.0 - 10.0	15	112	84
8.2 - 12.4	16	90	100
10 - 15	17	75	120
12.4 - 18	18	62	140
15 - 22	19	51	180
18 - 26.5	20	42	220
22 - 33	21	34	260
26.5 - 40	22	28	320
33 - 50	23	22	400
40 - 60	24	19	500
50 - 75	25	15	620
60 - 90	26	12	740
75 - 110	27	10	900
90 - 140	28	8	1200



There are three designated waveguide size ranges.

'WG' & 'WR' numbers are most widely used, with 'R' numbers being rarely used nowadays, but included here for reference.

'WG' numbers are mainly used in the UK and Europe, with 'WR' sizes used in the US and the Far East.

We are more than happy to work with whatever waveguide numbers our customers specify whether it is WG, WR or R.

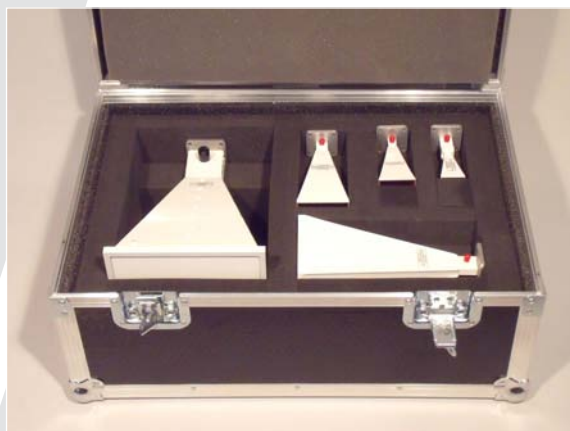

# Waveguide/Standard Gain Horns



These precision standard gain horns are manufactured from brass, copper or aluminium alloy. The horns come in three ranges with nominal gains at mid-band of 10, 15 and 20 dBi with a spread of about 3 dB across the frequency band. A full test report including antenna gain, beamwidth, and VSWR is supplied with each horn. The horns are normally fitted with an integral coaxial-to-waveguide transition, but can be supplied with a waveguide flange.

Mounting brackets are included at no extra cost. Non standard gains and frequency bands are also available.

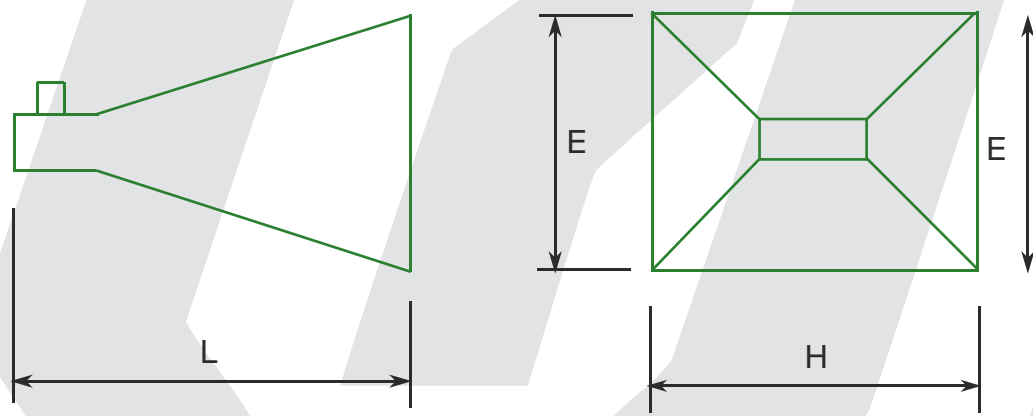

Flanged antennas will have a shorter length  $L$  than stated in the table as they will not have the coaxial transition section.

Note :- N = N-type connector, F = Waveguide Flange, S = SMA connector, K = K-type, V = V-type, all are Female (Jack) unless otherwise stated.

### Q-par Angus Numbering Guide

## QSH12N10

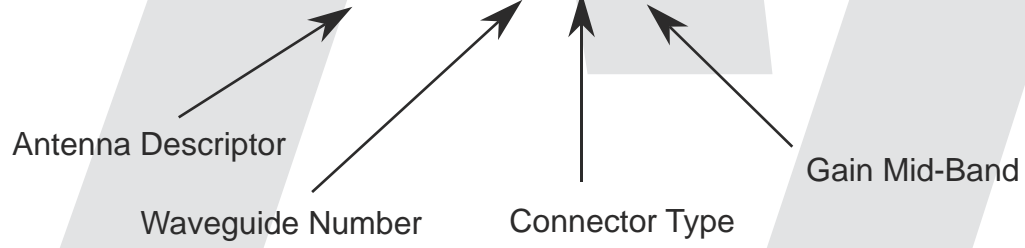

# Standard Gain Horn Specifications

Power rating shown is for Type N connector, unless otherwise stated.

Frequency GHz	Part Number	Gain (dBi)	Power (W c.w)	Connectors	H (mm)	E (mm)	L (mm)
0.75 - 1.1	QSH4#15	15	425	N/F	800	600	1025
0.9 - 1.5	QSH5#10	10	400	N/F	344	250	510
	QSH5#15	15	400	N/F	590	470	960
	QSH5#20	20	400	N/F	1180	850	2300
1.1 - 1.7	QSH6#10	10	350	N/F	310	230	545
	QSH6#15	15	350	N/F	510	400	820
	QSH6#20	20	350	N/F	960	705	1800
1.4 - 2.2	QSH7#10	10	280	N/F	245	180	425
	QSH7#15	15	280	N/F	400	320	640
	QSH7#20	20	280	N/F	670	470	1340
1.7 - 2.6	QSH8#10	10	260	N/F	205	150	345
	QSH8#15	15	260	N/F	330	260	525
	QSH8#20	20	260	N/F	575	410	1200
2.2 - 3.3	QSH9A#10	10	240	N/F	160	120	270
	QSH9A#15	15	240	N/F	260	210	410
	QSH9A#20	20	240	N/F	450	320	930
2.6 - 4.0	QSH10#10	10	210	N/F	140	100	230
	QSH10#15	15	210	N/F	220	180	345
	QSH10#20	20	210	N/F	380	270	750
3.3 - 4.9	QSH11A#10	10	200	N/F	110	85	185
	QSH11A#15	15	200	N/F	180	145	280
	QSH11A#20	20	200	N/F	300	215	615
3.9 - 5.9	QSH12#10	10	180	N/S/F	95	70	150
	QSH12#15	15	180	N/S/F	150	120	230
	QSH12#20	20	180	N/S/F	250	180	530
4.9 - 7.1	QSH13#10	10	160	N/S/F	80	60	125
	QSH13#15	15	160	N/S/F	125	100	190
	QSH13#20	20	160	N/S/F	200	150	460
5.8 - 8.2	QSH14#10	10	145	N/S/F	65	50	110
	QSH14#15	15	145	N/S/F	105	85	165
	QSH14#20	20	145	N/S/F	175	125	390

Frequency GHz	Part Number	Gain (dBi)	Power (W c.w.)	Connectors	H (mm)	E (mm)	L (mm)
7.0 - 10.0	QSH15#10	10	135	N/S/F	55	40	90
	QSH15#15	15	135	N/S/F	85	70	135
	QSH15#20	20	135	N/S/F	145	105	320
8.2 - 12.4	QSH16#10	10	120	N/S/F	45	35	75
	QSH16#15	15	120	N/S/F	75	60	110
	QSH16#20	20	120	N/S/F	120	85	265
10.0 - 15.0	QSH17#10	10	110	N/S/F	40	30	60
	QSH17#15	15	110	N/S/F	60	50	90
	QSH17#20	20	110	N/S/F	100	70	220
12.4 - 18.0	QSH18#10	10	100	N/S/F	35	25	55
	QSH18#15	15	100	N/S/F	50	40	80
	QSH18#20	20	100	N/S/F	80	60	175
15.0 - 22.0	QSH19#10	10	30 (SMA)	S/F	30	20	45
	QSH19#15	15	30 (SMA)	S/F	45	35	65
	QSH19#20	20	30 (SMA)	S/F	70	50	150
18.0 - 26.5	QSH20#10	10	20 (SMA)	K/S/F	25	18	35
	QSH20#15	15	20 (SMA)	K/S/F	35	30	55
	QSH20#20	20	20 (SMA)	K/S/F	55	40	130
22.0 - 33.0	QSH21#10	10	40 (K)	K/F	18	13	30
	QSH21#15	15	40 (K)	K/F	28	20	45
	QSH21#20	20	40 (K)	K/F	44	32	105
26.5 - 40.0	QSH22#10	10	40 (K)	K/F	17	15	30
	QSH22#15	15	40 (K)	K/F	27	20	45
	QSH22#20	20	40 (K)	K/F	37	26	95
33.0 - 50.0	QSH23F20	20	330 (F)	F/V	34	26	80
40.0 - 60.0	QSH24F20	20	300 (F)	F/V	24	18	70
50.0 - 75.0	QSH25F20	20	280 (F)	F/V	20	15	60
60.0 - 90.0	QSH26F20	20	240 (F)	F	18	13	53
75.0 - 110.0	QSH27F20	20	220 (F)	F	15	11	45
90.0 - 140.0	QSH28F20	20	200 (F)	F	12	9	35

# Standard Gain Horn Specifications

# Wideband Horn Antennas

These horns offer an unrivalled facility for EMI / RFI testing, evaluation & electronic surveillance. Bandwidths range from 1 to 40 GHz with single and dual polarised antennas.

The horns are normally fitted with an integral coaxial connector. The broadband ridged horns that are compatible with WRD ridged waveguide can also be supplied with a waveguide flange.

Described overleaf are just some of the models that we produce. We are happy to discuss any specific frequency band, gain or beamwidth requirements you may have.



## Low Frequency Horns 100 MHz - 2 GHz

Q-par Angus are world leaders in the design and construction of large, low frequency, wide-band, double and quadruple ridged horns. The examples shown are dual polarised antennas operating over the frequency ranges 220 MHz - 2 GHz, 100 MHz - 1 GHz and 100 MHz - 1.8 GHz.

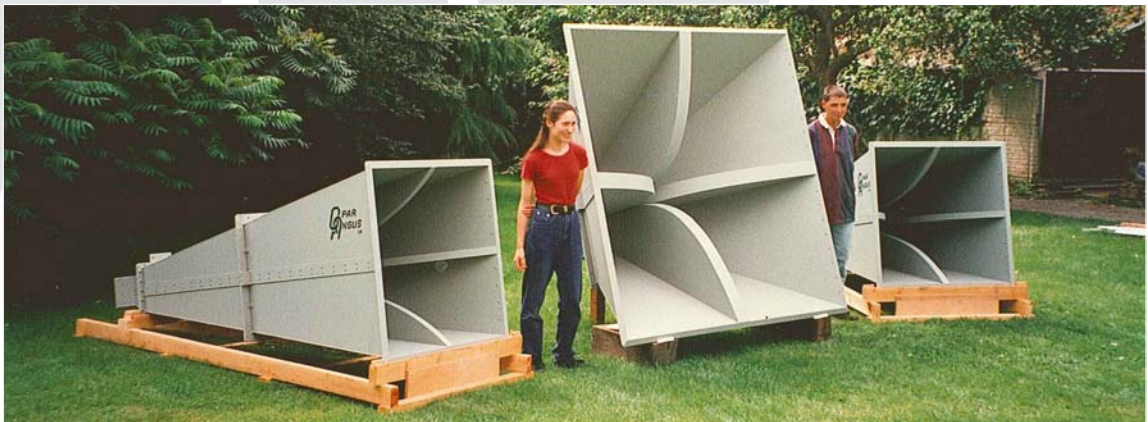

The 100 MHz to 1 GHz Double Ridged Horn Antenna is manufactured from aluminium. It is ideal for Wide Band surveillance, susceptibility and EMC applications. The horn is supplied with a precision type 'N' connector. Gain varies from 4 - 10 dBi across the frequency band.

A detailed test report is provided with each horn.

Customised mounts can be supplied to your specific requirements.

# Wideband Horn Specifications

Flanged antennas will have a shorter length L than stated in the table as they will not have the coaxial transition section.

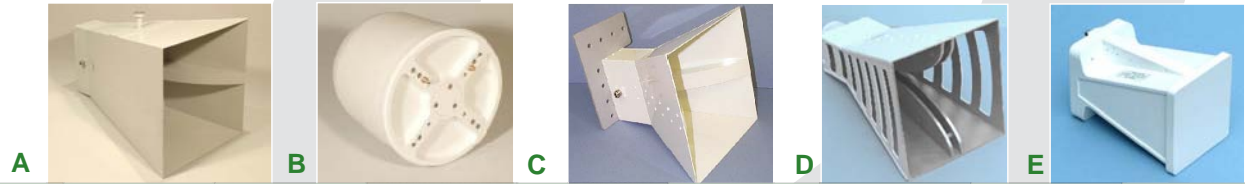

	Frequency (GHz)	Part Number	Gain (dBi)	Power (W c.w.)	Connector Options	VSWR	Isolation (dB)	Beamwidth (degrees)	Weight (kg)	H (mm)	E (mm)	L (mm)
A	0.5 - 2.5	WBH0.5-2N13	7.4 - 14.5	250	N	< 1.8 :1 (95 % of band)	N/A	70 - 25	9.7	404	404	570
B	0.9 - 18	WBHDP0.9-18S Dual Polarised	4.5 - 13.4	40	S	< 2:1	> 25	120 - 20	1.7	215 mm Diameter		230
C	1 - 2	WBH1-2N10	7 - 12	300	N	< 1.8:1	N/A	60 - 35	3.0	285	281	290
D	1 - 8	WBH1-8B10HP	5.5 - 16.8	1.5 kW c.w	7/8" IEC	< 1.7:1	N/A	80 - 15	1.7	185	182	325
E	1 - 18	WBH1-18S	1.3 - 12.8	40	S	< 2:1	N/A	280 - 20	0.7	96	90	148
	2 - 4	WBH2-4#17	16.4 - 18.1	10 kW peak 750 W c.w.	SC / F	< 1.6:1	N/A	25 - 15	15.8	555	426	986
F	2 - 8	WBH2-8#13	11.5 - 15	100 (N)	S / N / SC	< 1.6:1	N/A	56 - 20	1.9	215	215	325
G	2 - 18	WBH2-18#	7 - 13	20 (S) 50 (N)	S / N	< 2.5:1	N/A	90 - 10	0.37	119	86	119
	2 - 18	WBH2-18#HG	10 - 21	50 (S) 80 (N)	S / N	< 2:1 typ.	N/A	60 - 9	2.7	165	165	622
	2 - 18	WBHDP2-18# Dual Polarised	6.8 - 18	40 (S)	S / N	< 2.5:1 typ.	> 25	70 - 12	2.5	125	125	304
	2 - 18	WBHDP2-18#HG Dual Polarised	10.6- 22.4	40 (S)	S / N	< 2.5:1 typ.	> 20	56 - 8	1.9	174	174	440
G	2 - 24	WBH2-24S	7 - 13	20 (S)	S	< 2.5:1 typ.	N/A	90 - 10	0.37	119	86	119
	4 - 8	WBH4-8#20	18.4 - 20.9	2 kW (F) 50 (S)	F / S	<1.3:1 (F) < 1.7:1 (S)	N/A	17 - 11.3	7.6	367	285	890
H	6.5 - 18	WBH6.5-18#15	8.8 - 17	50 (S) 400 (N) 2 kW (F)	F / S / N	< 1.5:1 (N)	N/A	60 - 20	0.8	57	47	222
	7.5 - 18	WBH8-18#20	20.2 - 21.4	2 kW (F)	F / S / N	< 1.2:1 (F)	N/A	14 - 20	3.4	183	143	420
I	18 - 40	WBH18-40#	12.3 - 14.8	200 (F) 20 (K)	F / K	< 1.6:1 (K)	N/A	43 - 24.6	0.14	35	28	73
J	18 - 40	WBHDP18-40K Dual Polarised	12 - 16.9	20	K	< 2.5:1 typ.	> 25	41 - 20	0.25	47	47	68



N = N-type connector  
 F = Waveguide Flange  
 SC = SC connector  
 S = SMA connector  
 K = K-type connector  
 HG = High Gain  
 B = 7/8" IEC connector  
 All are Female (Jack) unless otherwise stated.

Q-par Angus Ltd have teamed up with TMD Technologies Ltd to produce a range of unrivalled antenna and amplifier solutions that exceed the latest DO160 HiRF specifications.

The horn antennas have been specially developed by Q-par Angus to focus the RF energy at short distances from the aperture, and thus overcome the near field limitations of traditional designs.

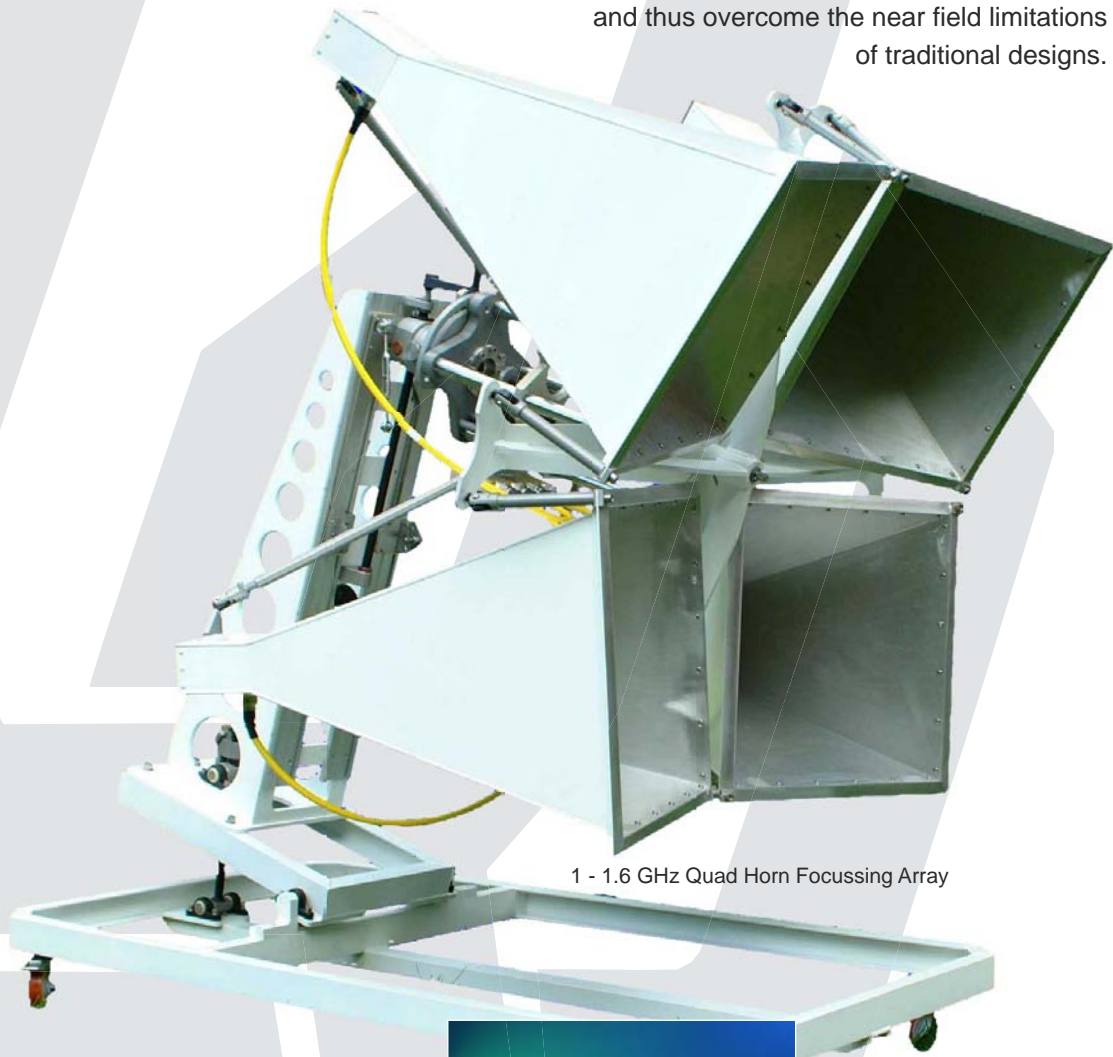

1 - 1.6 GHz Quad Horn Focussing Array

Nine specialised antennas cover the frequency range 0.4 - 18 GHz. Six amplifiers cover the 1 - 18 GHz range, each having output powers in excess of 4 kW. 3 kV/m or more is now achievable at 1 metre in free field tests. 3 dB spot sizes are 150 mm or greater. All exceed latest Category K specification.

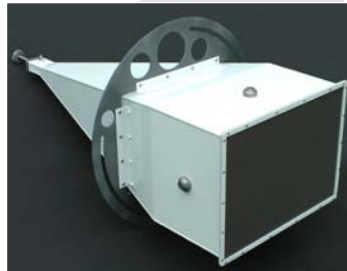

Various connector options are available. Power ratings will depend on connector type.

Many other frequency bands and 'specials' have been designed in addition to these antennas listed, please feel free to contact us if you have a particular specification or requirement.

**B** 1 - 1.6 GHz Quad Horn Focussing Array



**A**

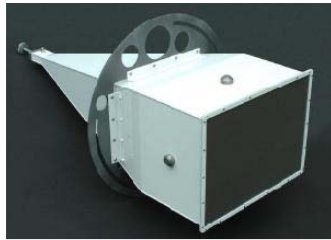

**C**



**D**



**E**



	Frequency (GHz)	Part Number	Gain (dBi @ 1m)	Input Power	Mean Power Rating	Peak Power Rating	VSWR	-3dB BW @1m (mm)	~Weight (kg)	H (mm) approx	E (mm) approx	L (mm) approx
A	0.4 - 1	QHIRF0.4-1#14	11.6 - 15.8	0.5 - 1.1 kW for 700 V/m	2 kW 7:16 DIN 1.5 kW (SC) 1 kW (N)	13 kW 7:16 DIN 10 kW (SC) 5 kW (N)	< 1.5:1 typical 2:1 max.	260 - 660	60	1400	1400	900
B	1 - 1.6	QHIRF1-1.6#20	18.9 - 20.6	2.8 - 3.8 kW for 3 kV/m	1.6 kW 7:16 DIN 1.2 kW (SC) 0.8 kW (N)	13 kW 7:16 DIN 10 kW (SC) 5 kW (N)	< 1.5:1 typical 2:1 max.	182 - 296	60	1250	1250	900
B	1.5 - 2.6	QHIRF1.5-2.6#21	20.3 - 22	2.5 - 2.8 kW for 3 kV/m	1.4 kW 7:16 DIN 1 kW (SC) 0.7 kW (N)	13 kW 7:16 DIN 10 kW (SC) 5 kW (N)	< 1.5:1 typical 2:1 max.	156 - 246	40	950	950	900
C	2 - 3.2	QHIRF2-3.2#20	20.0 - 20.9	2.4 - 2.9 kW for 3 kV/m	1.2 kW 7:16 DIN 0.9 kW (SC) 0.6 kW (N)	13 kW 7:16 DIN 10 kW (SC) 5 kW (N)	< 1.5:1 typical 2:1 max.	210 - 335	16	700	500	1650
C	2.6 - 4	QHIRF 2.6-4#22	20.2 - 22.8	1.6 - 2.3 kW for 3 kV/m	1.2 kW 7:16 DIN 0.75 kW (SC) 0.5 kW (N)	13 kW 7:16 DIN 10 kW (SC) 5 kW (N)	< 1.5:1 typical 2:1 max.	204 - 304	7.5	470	350	1150
C	4 - 6 (min)	QHIRF4-6#22	21.1 - 23.6	1.3 - 2.3 kW for 3 kV/m	0.8 kW 7:16 DIN 0.6 kW (SC) 0.4 kW (N)	13 kW 7:16 DIN 10 kW (SC) 5 kW (N)	< 1.5:1 typical 2:1 max.	170 - 260	4.6	400	300	900
D	6 - 8.2	QHIRF6-8.2#22	21.8 - 23.1	1.5 - 2.0 kW for 3 kV/m	0.5 kW (SC) 0.32 kW (N)	10 kW (SC) 5 kW (N)	< 1.5:1 typical 2:1 max.	180 - 240	3.6	280	190	1080
E	8 - 12.4	QHIRF16F22	20.7 - 23.3	1.4 - 2.5 kW for 3 kV/m	10 kW (F)	10 kW (F)	< 1.5:1 typical 2:1 max.	200 - 300	1.1	170	110	530
E	12.4 - 18	QHIRF18F22	21.6 - 23.2	1.4 - 2.1 kW for 3 kV/m	10 kW (F)	10 kW (F)	< 1.5:1 typical 2:1 max.	180 - 250	1	120	85	300

# HiRF Horns Specifications

# Applications

## Testing

Our standard gain horns provide accurate gain/beamwidth and repeatability - a critical requirement for test & measurement applications.

## EMC

High power or focussed arrays of our antennas provide excellent immunity testing capability.

## Links

Q-par horns used in short range, line of sight microwave links have been deployed indoors & in outdoor locations such as sports stadia.

## Defence

Q-par has extensive experience providing rugged & custom designs for ECM, surveillance and other applications.

## Environment

Our horns have been used in environmental and climatic monitoring systems.



Whether you require a standard gain horn antenna from stock or a fully researched, designed and tested horn, tailored to your specific needs, Q-par Angus is able to offer a discreet, comprehensive and efficient service, that has been developed over more than 35 years serving the RF industry and which carries a reputation for reliability & innovation.